

DESIGN AND DEVELOPMENT OF A SMART MIRROR USING RASPBERRY PI

¹VAIBHAV KHANNA, ²YASH VARDHAN, ³DHRUV NAIR, ⁴PREETI PANNU

^{1,2,3}B.Tech Student, ⁴Assistant Professor, Department of ECE, SRM University, NCR Campus
E-mail: ³dhrvusatish11@gmail.com

Abstract - This paper presents the design and the development of an interactive multimedia futuristic Smart Mirror with artificial intelligence for the ambient home environment as well as for commercial uses in various industries. The project which would collect real world machine data and the data would be transmitted from the machine and would be managed by the Raspberry Pi. The Smart Mirror implemented as a personalised digital device equipped with peripherals such as Raspberry Pi, microphone, speakers, LED Monitor covered with a sheet of reflective one way mirror provides one of the most basic common amenities such as weather of the city, latest updates of news and headlines and local time corresponding to the location. Using speech processing techniques the Smart Mirror therefore interacts with the user through verbal commands, functions and listens to the user's question and responds them adequately.

Keywords - Smart Mirror, Raspberry PI, Artificial Intelligence, Weather, Time, News

I. INTRODUCTION

Interactive computing, with wirelessly connected embedded devices that are being used in various day-to-day activities, are changing and improving the standards of the quality of life. Based on this interactive computing and communication technologies, many devices/products are now emerging and with this multimedia intelligence it is providing comfortable, secure and convenient personal services everywhere whether it is home or various industries and making a lot of users comfortable. We look at the mirror daily and interact with it psychologically to find out how we look and how our attire is. The interactive mirror is a development effort to augment the mirror with proper embedded intelligence for offering enhanced features such as weather of the city, latest updates of news and headlines and local time corresponding to the location. The Smart Mirror would help in developing smart houses with embedded artificial intelligence, as well as finding its applications in industries. The remainder of this paper is organized as follows. Section 2 briefly comments on theory and some related works. This is followed by the description of the smart mirror including the design and architecture of the proposed Smart Mirror in Section 3. Conclusion and some thoughts on future work are presented at last.

II. THEORY

The vision of Ambient Artificial Intelligence (AmI) has brought a new twist to the decade old research and industry initiatives in realizing Smart Environments. The AmI vision, as proposed by the European Consortium [1], promotes a paradigm where humans are surrounded by intelligent and natural interfaces offered by the interconnected heterogeneous computing devices embedded into

everyday objects. The environment thus created is capable of recognizing and responding to the actions and presence of individuals. Therefore, AmI can be seen as the driving force toward a more user-friendly and user-empowered smart environment for providing effective support to human interactions.

The AmI aware smart environments and surrounding, whether it is the home environment or the distributed environment, uses a variety of smart technologies. These technologies integrate sensing, processing, reasoning, and networking capabilities in addition to heterogeneous applications, services and digital contents [2]. With all of these rich technologies involved, AmI faces challenges on how to integrate them with the everyday objects. Often unobtrusively, in order to provide computing intelligence in the surrounding environment.

The application of AmI in the home environment may provide quality, convenience, efficiency, security, and safety to its residents [5]. AmI for assisted living [6], especially for the elderly and the people with disabilities [7] has already received much attention. Besides, the areas of home automation, communication and socialization, rest, refreshment, entertainment and sports, working, and learning at home [8] will be influenced by the innovations of AmI. Therefore, the design of smart artefacts for the ambient homes should not be only technology-driven; it should also consider other aspects of home environment with a view to providing comfort and convenience to people living in the environment. Our work is geared towards this direction and is focused on the design and development of a smart mirror interface for the ambient home environment. In this paper we make the following contribution. We proposed and developed a functional prototype of the smart mirror using off-the-shelf technologies that provide personalized data feeds such as weather, time, and reminder. The mirror

can be used as a traditional mirror that essentially provides a sense of natural interaction with the surrounding environment and also we provide an easily extendable framework for integrating web services such as YouTube videos, interactive maps and checking a full week's weather with the mirror interface

The Artificially Intelligent Smart Mirror is designed to perform several functionalities that can be explained, it will mimic a natural mirror interface through a flat LED monitor used for the mirror display. A one-way mirror is used in front of the LED monitor thereby mimicking the function of a regular mirror. For personalised information services the users will be able to obtain minute updates of latest news and public headlines, weather reports as well as get reports of our interests [3].

III. RELATED WORK

The proposed smart mirror represents a natural interface that facilitates access to personalized services. This is an attempt to contribute to this design of a smart mirror-like interface as well as the smart environment in which the interface is used for interaction in the following, we briefly comment on some related research in this direction.

Philips HomeLab [4] is a testbed for creating perspective and context-aware home environments. Among several projects, their work on creating an intelligent personal care environment uses an Interactive Mirror [9] in the bathroom to provide personalized services according to the user's preferences. For example, children can watch their favourite cartoon while brushing their teeth. The mirror can provide live TV feeds, monitor the latest weather, and so on. The mirror is a combination of one or more LCD flat screen displays specifically combined with a mirrored surface and connected with a central processor to provide the intended services. The Interactive Mirror serves as a motivation to provide ambient feelings in the home environment.

The work in [10] proposes a Magical Mirror as an interface to provide basic services. The intended services to offer are interactive TV, specific weather data, and searches. Unlike our work, it promotes the use of ontology to personalize the services. However, conceptually, our work has similar objectivity to what the Magical Mirror intends to perform, except that we present a working prototype, whereas some of the functionalities in the Magical Mirror have been presented only by simulation. In addition, we use open standards like web services to communicate with the devices and customize various personalized services for the user, which is not present in the design of the Magical Mirror.

In comparison to the works described above, our work is different in that we aim to develop a working system for providing services in the ambient home environment based on open standards and off-the-shelf technology, where the smart mirror is the interface to access/control various data feeds, various information services.

IV. PROPOSED SMART MIRROR

Figure 1 shows a schematic view of the proposed smart mirror. The mirror is eventually a technologically augmented interaction device. The objective of designing the mirror is to provide a natural interface in the ambient home environment for accessing various services such as location based weather, time, calendar etc. as well as provide access to YouTube, Soundcloud, maps etc. The project includes downloading the Raspbian operating system based on Debian and extracting the image on SD card, inserting the card in the Raspberry PiSD slot and then performing the required steps.

We plan to deliver a working prototype i.e. design and development of a futuristic Smart Mirror on Raspberry Pi 3 for the ambient home environment as well as for commercial uses in various industries. Most people have mirrors at home, so the concept of a smart mirror that you can interact with is attractive and can be fantasized by anyone. At times no one has time to read the newspaper or switch on the TV right in the morning to check the news headlines or the weather forecast. If a mirror serves to this purpose, one can imagine the amount of time it will save and be of such a great use. The device was to look like a regular mirror but would have a screen inside. The project which would collect real world machine data such as location based latest news and headlines, weather reports, and as well as show us the local time. The data would be transmitted from the machine and would be managed in a central database. We have also worked on including Artificial Intelligence in the Smart Mirror wherein a Voice-enabled assistant will cater to the needs of the user.

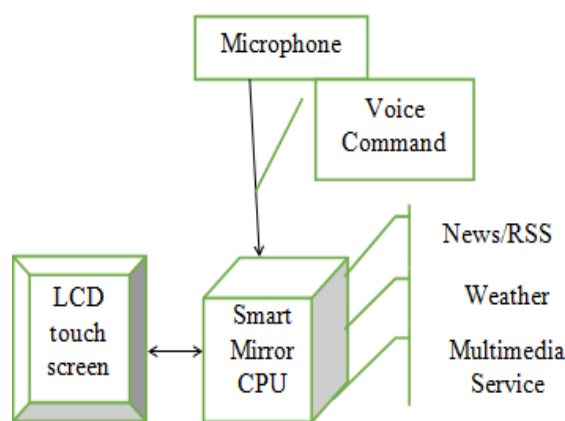

Fig 1 Circuit Diagram

V. FUNCTIONAL OVERVIEW

The proposed mirror is designed to perform i.e.: Fig 2, several functionalities that can be summarized as follows:

- a) Mimic a natural mirror interface:
- b) A flat monitor is used for the mirror display. A one way mirror is used to provide real time display of what is located in front of the Smart Mirror using Raspberry Pi thereby mimicking the function of a regular mirror.
- c) Personalised Information services:
Users will be able to obtain minute updates of latest news and public headlines, weather reports as well as get reports of our interests.
- d) Customized management of profiles:
Users can create their own profiles and store them in the system. According to this profile, customized services are provided to the user.

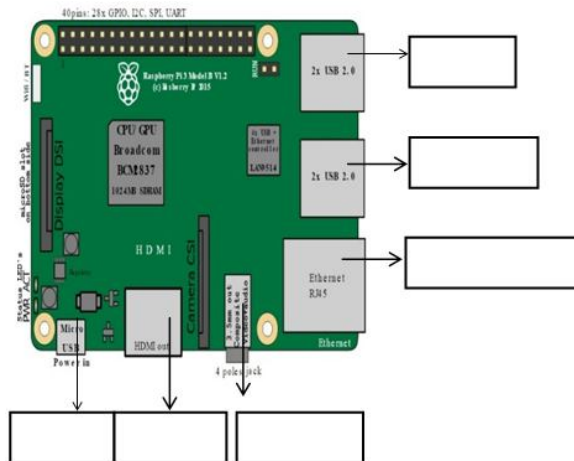

Fig 2 Block Diagram

CONCLUSION

We have designed a futuristic smart mirror that provides natural interaction between users and the ambient home services. The mirror display is provided by a flat LED display monitor which displays all the necessary information which are useful for the user. The mirror also provides a picture-in-picture sub-display to facilitate the display

of services such as maps, videos via YouTube. We have developed a functional prototype to demonstrate our work. Overall, the prototype provides an easily extendable framework that can be utilized to provide even more functionality to the user. In our future work we will investigate how the surrounding context of the user and the environment can be utilized in order to provide optimal service experiences in the home environment. The system can be made much more useful to the users by adding more functionality like integrating light settings, speech processing, etc.

REFERENCES

- [1] Adobe Flex 2 <http://www.adobecom/products/flex/>; accessed: February 2007.
- [2] ERCIM Working Group SESAMI, Smart Environments and Systems for Ambient Intelligence. <http://www.ics.forth.gr/sesami/>.
- [3] Memory Mirror <http://www.cc.gatech.edu/fcele/cl/projects/dejaVu/mnmjindex.html>.
- [4] Philips Homelab. <http://www.research.philips.com/technologies/misc/homelab/index.html>
- [5] M. S. Raisinghani, A. Benoit, J. Ding, M. Gomez, K. Gupta, V. Gusila, D. Power, and O. Schmedding. Ambient intelligence: Changing forms of human computer interaction and their social implications. *Journal of Digital Information*, 5(4), 2004.
- [6] F. Bomarius, M. Becker, and T. Kleinberger. Embedded intelligence for ambient-assisted living. *ERCIM News*, 67:19-20, 2006.
- [7] P.L. Emiliani and C. Stephanidis. Universal access to ambient intelligence environments: Opportunities and challenges for people with disabilities. *IBM SystemsJournal*, 44(3):605-619, 2005.
- [8] M. Friedewald, O. Da Costa, Y. Punie, P. Alahuhta, and S. Heinonen. Perspectives of ambient intelligence in the home environment. *Telematics and Informatics*, 22(3):221-238, 2005.
- [9] Tatiana Lashina. Intelligent bathroom. In *European Symposium on Ambient Intelligence (EUSAI04)*, Eindhoven, Netherlands, 2004.
- [10] L. Ceccaroni and X. Verdaguer. Magical mirror: multimedia, interactive services in home automation. In *Proceedings of the Workshop on Environments for Personalized Information Access - Working Conference on Advanced Visual Interfaces (AVI 2004)*, pages 10-21, New York, NY, USA, 2004. ACM Press.

★★★