

ENDOSCOPIC WASHER AND DISINFECTOR

SWARA VASHI

Biomedical Engineering Department, L.D. College of Engineering, India.
E-mail: swaravashi09@gmail.com

Abstract— Endoscope washers and disinfectors are used to process endoscopes which are not used in sterile areas of the body like G.I tract or colon which cannot be cleaned by terminal sterilization. With the rise in use of endoscopic procedures in diagnostic and surgical treatments, there is a call for safe cleaning modus operandi for endoscopes. To avoid the faux pas created due to improper manual cleaning, an automated method of disinfecting is the most effective method. A prototype is built using a comprehensible microprocessor controller Arduino Uno. The sanitation of is done according to the national standards for monitoring of hygiene and the guidelines provided for the reprocessing of the medical product. Endoscopes undergo five stages of cleaning namely leakage testing, washing, aeration, disinfecting and rinsing. This review paper gives an insight of the cost effective prototype built, its working and its merits over manual method of cleaning and disinfecting an endoscope.

Keywords— Endoscope washer, endoscope reprocessing, automatic cleaning, manual cleaning, Arduino Uno.

I. INTRODUCTION

An endoscope is an instrument that allows the doctor to see inside the human body by directly inserting it in the body. A medical procedure of using endoscope is called endoscopy. Endoscopes are categorised into different types depending upon the site of the body and the type of procedure undertaken. Due to increasing use of endoscopy, there is a dire need of cleaning, disinfecting and sterilizing the endoscopes so that the other patients are not infected.^[1] Endoscope washers and disinfectors precisely and effectively clean the endoscopes. In 1984 Wassenburg started developing an innovative endoscope washer disinfectant. In 1987 the first Wassenburg endoscope washer and disinfectant, named FDS-I (fiberscope disinfection system 1), was manufactured. Till date the concept of separate washing, disinfection and monitoring developed by Wassenburg still forms the basis of the endoscope washer and disinfectors. With the increasing demand for a better equipment and advances in the medical engineering field, the requirement of a sophisticated product grew. Fully automatic machines came into market which ceased human intervention. Automatic ultrasonic cleaners have also been developed recently which have very high efficiency.^[2]

The main objective of this invention is to provide an automatic endoscope washer to eliminate the risks generated due to improper manual cleaning and disinfection. Moreover it is made to provide a user friendly platform to the client to clean and disinfect their endoscope as per his needs. Furthermore the endoscope washer is made compact and affordable by using components that are easily available and are simple to maintain.

The system consists of five steps : leakage testing, washing, aeration, disinfection and rinsing. The model is designed in such a way that the user can alter the sequence of each cleaning step or can

perform only the cleaning step of their choice. Minor changes in the programming software allows the user to utilize the washer in fully automated mode and also permit them to exercise it in semi automated mode where manual cleaning is done in advance. Through the years, the washer has undergone innumerable changes in design. One which has dramatically changed the old school way of cleaning the devices is ultrasonic endoscopic washer.^[3] This system cleans the endoscope at higher frequencies which creates minuscule vacuum bubbles. These bubbles perform the task of cleaning by imploding inside the endoscope surface. This process is also known as cavitation. These minute bubbles provide micromechanical scrubbing action which reaches the remote areas and irregular surfaces to ensure proper and consistent cleaning. These cleaners are very efficient yet expensive.^[4]

II. METHODOLOGY

The components include DC valves, AC water pumps Arduino Uno board used as the microcontroller of the system, four and eight channel relay board, air compressor serial LCD, keypad and connectors. Arduino Uno controls the working of pumps, valves and air compressor with program written in C++ is installed in its software.^[5]

According to the figure 1, the sink is the hub where the endoscope is placed. Five solenoid valves are used which control the outflow of the water and the disinfectant into various channels of the system from the sink. Two separate water and disinfectant tanks are used to store water and disinfectant during washing and disinfection process respectively. Along with the tanks, pumps are used to draw the fluid from the tank into the sink via pipes. Air compressor is used to check the presence of leakage in the endoscope and also dry the scope.^[6] A battery which converts stored chemical energy to electrical energy is used to give power to run pumps.^[7]

The flowchart is a mere representation of the cleaning process of the endoscope. This process is divided into five categories mainly leakage testing, washing, aeration, disinfection and rinsing. A 4*3 matrix keypad is used where all the keys are initialised.^[8] The programme of all the cleaning steps is prewritten in the system software. Switch '1' denotes the first step of leakage testing. Leakage testing is done to test any leakage in the channels of endoscope. Air from the air pump is given to the endoscope through the ETO cap.^[9] Water is filled in the chamber through water supply pipe . Any leakage can be observed if bubbles are seen by the operator. Switch '2' denotes "washing", which is done to remove any impurities on the surface of the endoscope as well as to clean the inner channels. Water is also flushed in the channels through adapter for the adjusted time limit. Switch '3' denotes "aeration". It is done to make the channels dry. An air pump supplies air with adequate pressure to the air water channels adapters. Switch '4' denotes "disinfection", it is done using disinfectant chemicals available. Here the time limit is adjusted. The inner channels as well as the outer portion is thoroughly disinfected. Disinfectant is very costly^[10] and hence after each reprocessing cycle it is cleaned and thus reused. After a few cycles with the same disinfectant, it has to be drained out and new disinfectant has to be filled. Switch '5' denotes "rinsing". Scope is rinsed

and dried before using it again. To clear off the traits of the disinfectant. Switch '6' denotes "all off" means the whole system is ceased, switch '0' denotes the "auto mode" where all the five steps work back to back without the user intervention. The pumps and valves denoted as 'val' and 'P' with their corresponding numbers are high i.e. They are switched on and perform their task according to the cleaning process activated. When these valves and pumps are low, they are switched off and their action is terminated.^[11]

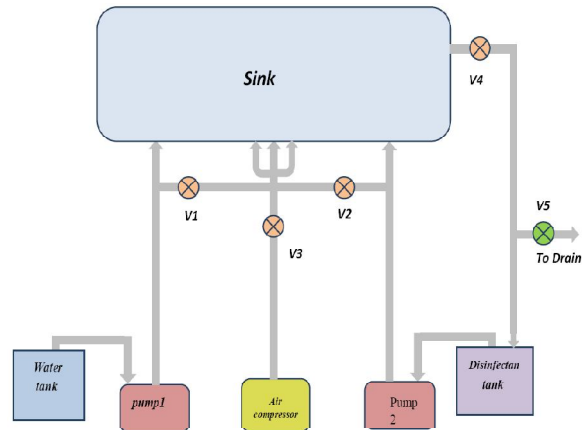

Fig 1. Schematic diagram of washer and disinfector

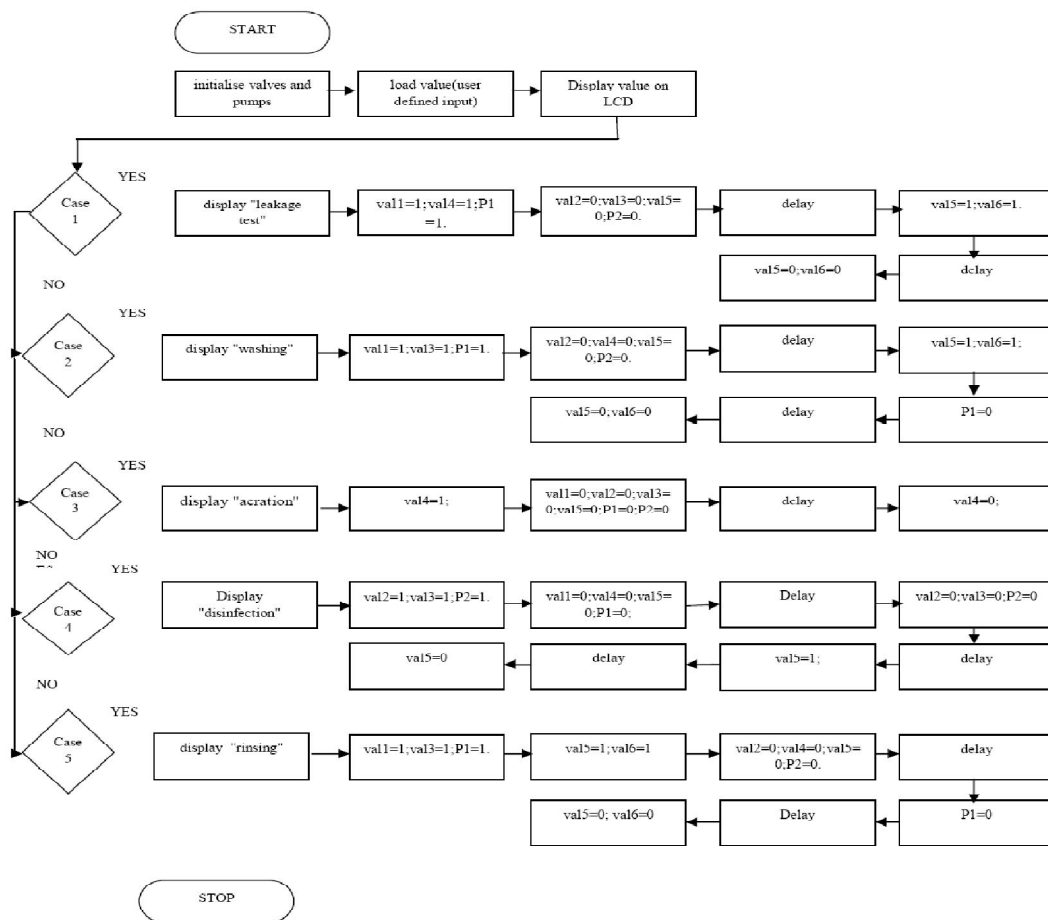

Fig. 2 Flowchart

III. VERIFICATION OF REPROCESSED ENDOSCOPE

One standard method to demonstrate conformity with accepted cleaning practices is the use of channel check test. This test detects residual carbohydrate, protein and haemoglobin remaining on endoscopes.^[12]

There are broadly two types of endoscopes. Flexible and rigid endoscopes. The latter are notoriously difficult to clean. There is a test to check the cleanliness of the biopsy channel of the flexible endoscope. The EndoChech™ is a miniature kit which is simple to use and infer. By wiping the biopsy channel of the flexible scope with the long probe, clip off the swab into the vial. The activating agent has to be mixed vigorously. A change in colour is observed. Depending on the type of test used, a colour change indicates that blood residue or protein residue remains in the channel and should be reprocessed.^[13]

IV. DISCUSSION

The project used Arduino Uno board instead of commonly used microcontroller 8051 or a few other such microcontroller processor because it seemed very simplified for any beginner to use and is relatively inexpensive.^[8]

Different types of valves were tested and on the basis of the experiments, DC solenoid valve was chosen owing to its easy electromechanical operation and availability. Initially AC submersible pumps were used instead of self priming monoset pumps. Working with submersible pump was difficult since it required to be submerged in the water, the head of the pump used was less due to which the required output was not achieved. The pumps that were later used had more head through which the required output was acquired. Pneumatic spiral pipes were used for the experimental purpose. Due to excessive leakages, the pipes were replaced and straight pneumatic pipes were used instead. With unremitting trial and error methods, the final structure of the project was prepared.

Automated systems claim to be more effective in removing bacteria than manual methods. Despite the results, the automated systems possess several drawbacks. The systems available in the market have their own wash cycles prior to disinfection. These systems also require manual pre-cleaning of endoscopes. Moreover it is necessary to check the compatibility of the endoscope and the disinfectant used. Furthermore, automated systems require regular maintenance which is time consuming and expensive. Some parts of the decontamination process like brushing lumens and wiping insertion tubes cannot be

automated and thus manual cleaning is a prerequisite.^[14]

When compared with the existing endoscopic washers in the market, this project has tried to fulfil its major applications. The five washing and disinfecting steps have been executed, its compact size and user friendly nature are the attributes that the project and the model available in the market share in common.

A comprehensive and robust endoscopic washer should have high efficiency and accuracy. The existing approaches have not fully satisfied the accuracy as well as robustness of a washer system. However, the current approaches do provide a framework to further develop techniques as well as modify the existing algorithms to achieve better performance. The programming technique used in the present system is simple and easy to understand. Moreover the components used are affordable. The model on the whole is cost effective.

CONCLUSION

The endoscopic washers are made to clean and disinfect the endoscopes used in surgery. There are two techniques that the washers in the market use. Manual cleaning and automatic cleaning.^[15] In our system, we have incorporated both automatic and semi automatic mode of cleaning since both the modes of cleaning makes it easier for the doctor and his assistants to use the model based upon the need and convenience. The present techniques use a controller operated software to run through the various washing and cleaning steps of the endoscope and Arduino Uno is used as our operating microcontroller. It has several advantages over the regular endoscopic washers. The interface of the controller is user friendly. The user comes to know about the step that is being performed. Moreover any changes to be made by the engineer in the system or by the programmer in the functional steps can be made easily through the controller. The prototype of the endoscope washer and disinfectant that is made has cost way lesser than the market value of the endoscope washer and disinfectant machines available currently. The use of four and eight channel relay circuits, air compressor, solenoid valves and pumps aggravates its feasibility. The project provides an efficient base for further development and enhancement of the product.

REFERENCES

- [1] Brend Krekamp, Oliver Kirschberg, Andreas Scheduling, Dieter Emmerich, Stefanie Klien, Thomas Sears. "Computer aided recording of endoscope washing and disinfection processes as an integral part of medical documentation for quality assurance purpose." BMC Gastroenterology.
- [2] <http://www.wassenburg.nl/about-us-content/104-history>.

- [3] <http://www.olympusglobal.com/en/corc/history/story/endo/future/index.html>.
- [4] Marie Mean, Marie Reine Mallaret, Philippe Bichard Jacqueline Shum, Jean-Pierre Zarski "*Gastrointestinal endoscopes cleaned without detergent substance following an automated endoscope washer/disinfector dysfunction.*"
- [5] <http://docsasia.electrocomponents.com/webdocs/0e8b/0900766b80e8ba21.pdf> arduino.
- [6] <http://www.harborfreight.com/12-volt-250-psi-compact-air-compressor>
- [7] http://www.automacbattery.in/exide_two_wheeler_exide_xtreme.html
- [8] <http://www.engineersgarage.com/microcontroller/8051projects/interface-keypad-AT89C51-circuit>
- [9] [http://www.electronicoscaldas.com/datasheet/JQC-3FC\(T73\)DC12V_JIHJK.pdf](http://www.electronicoscaldas.com/datasheet/JQC-3FC(T73)DC12V_JIHJK.pdf)
- [10] http://www.cdc.gov/hicpac/disinfection_sterilization/3_0_disinfectequipment.html
- [11] http://www.janatics.com/simple/images/Directional_Control_Valves/J%20series%20valve.pdf
- [12] <http://www.infectioncontrolday.com/article/check-verification-test-as-a-tool-to-assess-endoscope-cleanliness.aspx>
- [13] <http://www.hmark.com/endocheck.php>
- [14] J. Richards*y, R. Spenceryz, A. Fraiseyx, J. Lee{, P. Parnellk
- [15] Michelle J Alfa, Pat DeGagne, Nancy Olson and Iram Fatima "*Endoscope cleaner and reprocessor (ECR) simulated-use and clinical-use evaluation of cleaning efficacy.*" BMC Infectious Diseases

★ ★ ★

★ ★ ★